

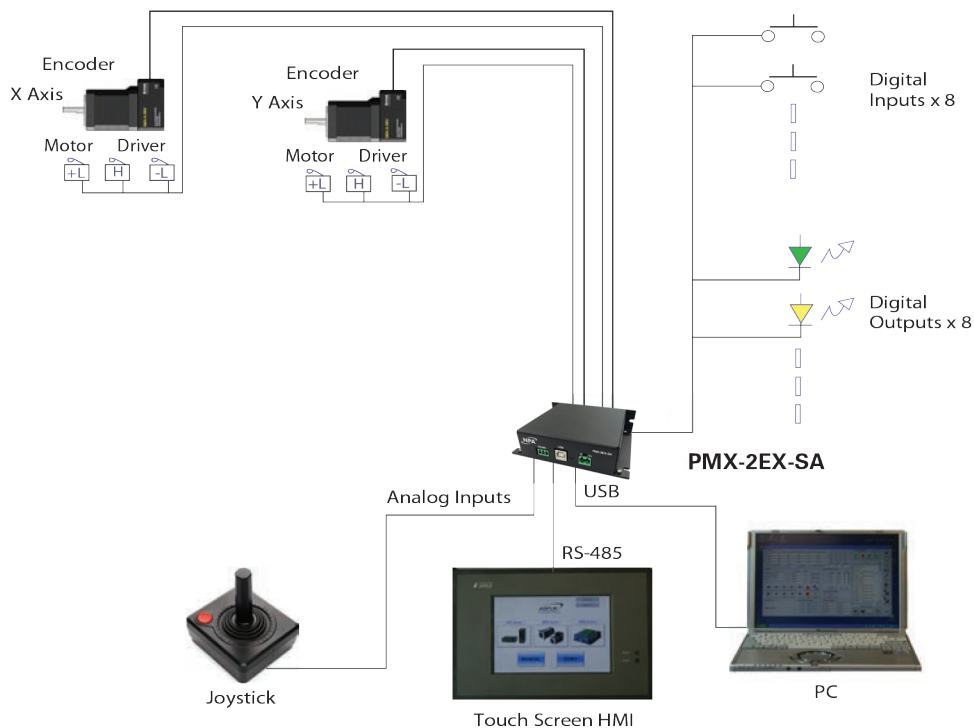

Specifications

- 2 Axis Advanced Motion Controller
- USB 2.0 and RS-485 Communication
- 6M maximum pulse rate output
- Trapezoidal or s-curve acceleration
- On-the-fly speed change
- XY linear coordinated motion
- Homing using Home and/or Index encoder channel
- Opto-isolated +Limit, -Limit, and Home inputs per axis
- Pulse/Dir/Enable open collector outputs per axis
- Single-ended or differential quadrature encoder inputs per axis
- Opto-isolated Digital Inputs (8)
- Opto-isolated Digital Outputs (8)
- Analog Inputs 10-bit resolution (2)
- Built-in joystick control for XY axes
- Built-in StepNLoop closed loop control algorithm
- BASIC-like standalone programming language
- Multi-task programming support



PMX-2EX-SA

Advanced 2-Axis Motion Controller with USB/RS-485 Communication

Electrical Interface

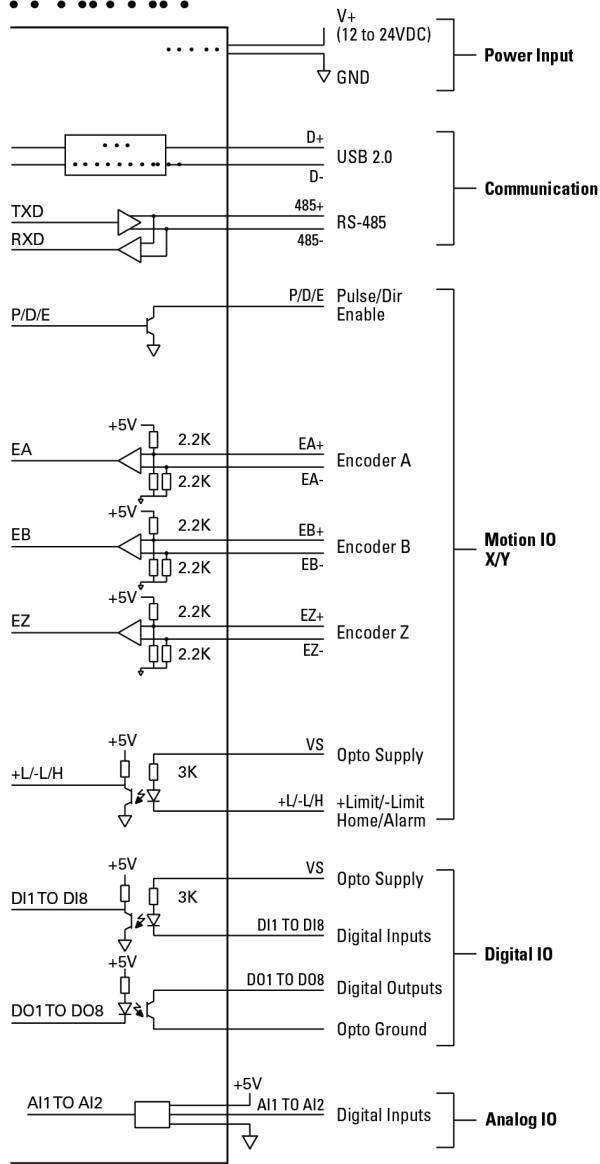

Dimensions

